



User Manual

SUBMERSIBLE PUMP

ENGLISH

TABLE OF CONTENTS

	<u>PAGE(S)</u>
INTRODUCTION	2
COMPONENTS NEEDED FOR INSTALLATION	2
PUMP CONNECTIONS & INSTALLATION INSTRUCTIONS	3-5
PARTS LIST and REPLACEMENT PART KITS	6
SUBMERSIBLE PUMP ASSEMBLY DRAWING	7
BEFORE REQUESTING SERVICE "Helpful Hints"	8
PUMP REMOVAL and DISASSEMBLY	9-10
PUMP RE-ASSEMBLY	11-13
APPLICATION WORKSHEET and FLOW CHARTS	14-15
TECHNICAL SPECIFICATIONS	16
TOOLS REQUIRED FOR INSTALLATION & MAINTENANCE	17
WARRANTY	18

INTRODUCTION

This manual has been provided as an aid to the operator with information about installing, operating, and servicing of the SINGFLO 2440 Series Submersible Pump. The engineers and technicians who designed and manufactured these pumps have developed these instructions from their experiences.

These instructions should be read completely before installing your new pump. Keep this manual readily available at all times for use when installing, operating, or servicing your pump.

For proper placement in the well refer to the application worksheet on pages 14-15.

This pump is not to be used with flammable liquids.

<input checked="" type="checkbox"/>	<u>COMPONENTS NEEDED FOR INSTALLATION</u>	<u>PAGE(S)</u>
<input type="checkbox"/>	CABLE TYPE	3
<input type="checkbox"/>	COUPLER AND DISCHARGE FOR OUTLET	4
<input type="checkbox"/>	SAFETY LINE	5
<input type="checkbox"/>	POWER SUPPLY	15-16
<input type="checkbox"/>	FUSE: RECOMMENDED SIZE AND TYPE	16
<input type="checkbox"/>	TOOLS REQUIRED	17
<input type="checkbox"/>	CONTROLLER: Use of an LCB (Linear Current Booster) Unit is required for optimum performance.	
<input type="checkbox"/>	COMPLETE APPLICATION WORKSHEET	14-15

I. PUMP CONNECTIONS & INSTALLATION INSTRUCTIONS

WARNING: IMPROPER INSTALLATION WILL VOID WARRANTY.

1) Select proper jacketed cable size (Fig.1).

Note: DO NOT select cables with irregular shapes, rough or grooved surfaces.

Use a #10 AWG jacketed Submersible cable that fits into the general size requirements shown (Fig 1).

RECOMMENDED CABLE TYPE	MINIMUM DIMENSION OF CABLE	MAXIMUM DIMENSION OF CABLE
FLAT PARALLEL	<p>.22 N (5.5 mm)</p> <p>.42 N (10.5 mm)</p>	<p>.32 N (8.0 mm)</p> <p>.58 N (14.5 mm)</p>
ROUND	<p>.35 N (9.0 mm)</p>	<p>.45 N (11.5 mm)</p>

FIGURE 1

2) Assemble Cable Boot (Fig. 2, 3, 4).

- Strip the outer cable jacket (Part A - not included) 2.0 in. (5 cm) (Fig. 2).
- Cut one of the lead wires 1.0 in. (2.5 cm) (Fig. 3).
- Wrap electrical tape around the cable. Start 2 in. (5 cm) below outer cable jacket and continue to taper to a point past the end of lead wires (Fig. 4).

Generously lubricate the cable 4 to 6 in. (10 to 15 cm) with supplied O-Ring grease.

- Slide the cable boot components over the cable (Part A) in the following order (Fig. 4).
 - Nut (Part D). Make sure threads are toward pump end of cable.
 - Outer Cable Boot (Part C). Small end first.

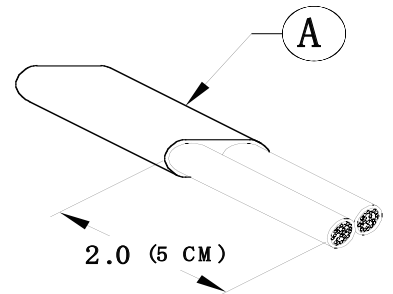

FIGURE 2



FIGURE 3

NOTE: Re-lubricate cable as necessary.

- Inner Cable Boot (Part B). Small end first.
- Remove tape and cut the lead wires back leaving about .50 in. (1.3 cm) exposed. Strip the inner conductor jacket .50 in. (1.3 cm) (Fig. 5).

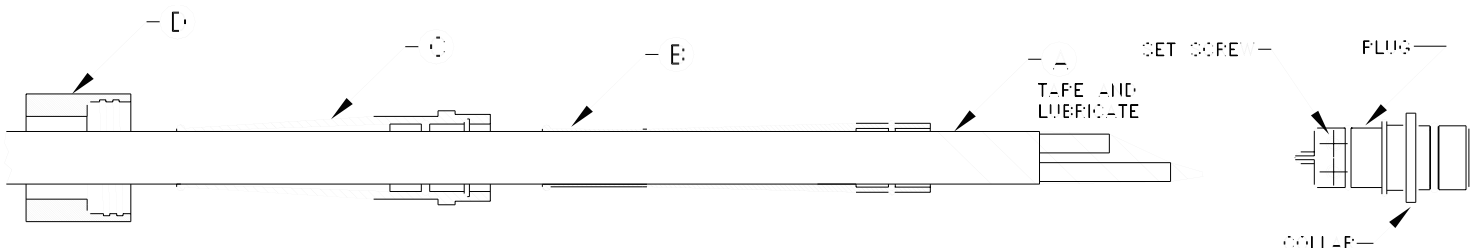

FIGURE 4

f) Insert the wire leads into Plug (Cable Adapter) connectors.
Using a 5/64" Allen Wrench tighten the set screws (Fig. 6).

g) Slide the Inner Cable Boot (Part B) over the plug until it is flush with the first step on the collar (Fig. 6).
Wipe the grease from the surface of Inner Cable Boot and cable.
Tape end of Inner Cable Boot tightly to the cable.
Be sure to tape 4 in. (10 cm) below the Inner Cable Boot on the cable.

Note: This taped area allows the Outer Cable Boot (Part C) to slide freely over the Inner Cable Boot. DO NOT REMOVE THE TAPE.

h) Lubricate the outer surface of the Inner Cable Boot and tape with supplied O-Ring grease.
Slide the Outer Cable Boot (Part C) over the Inner Cable Boot until it is flush with the second step on the collar (Fig. 6).

i) Push the Plug (Cable Adapter) into the Receptacle (Cable Adapter) until the collar is seated flush.

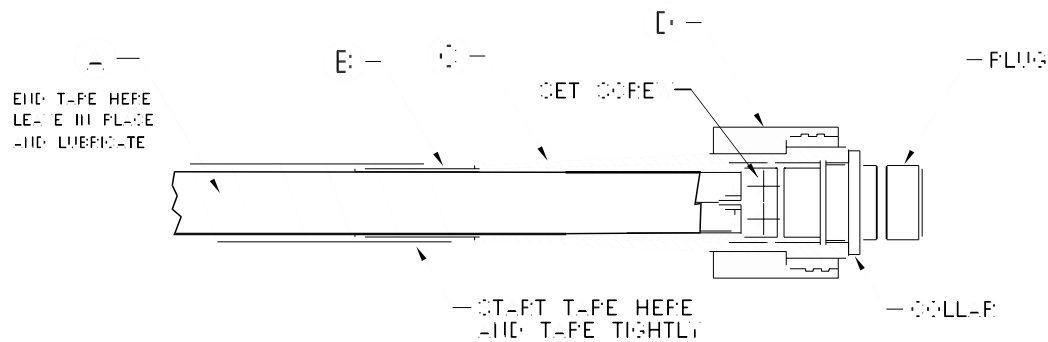

FIGURE 6

Note: The orientation of the Plug(Cable Adapter) will not effect the pumps performance.

j) Push the Nut (Part D) over the Plug (Cable Adapter) and then finger tighten the nut.

Note: Before continuing, operate the pump to check all electrical connections, using the correct power supply. Refer to Technical Specifications (Pg. 14).

If pump does not operate Refer to "**Helpful Hints**" (Page 8) before continuing .

3) Install the 6 in. hose and fitting (1/2" NPT X 1/2" BARB) (Fig. 7, page 5).

- a) Press the fitting into the 6 in. hose, slide the clamp on the hose and over the fitting and tighten the clamp securely.
- b) Slide another clamp on the 6 in. hose, slide the assembly over the barbed fitting on the pump, and tighten the clamp securely.

Note: Select the proper adapter hose and accessories for the pump.
USE OF DISCHARGE PIPE LARGER THAN 3/4" IS NOT RECOMMENDED..

Use 150 P.S.I. Min. (10 bars) working pressure rated 1/2 in. I.D. (12.7 mm I.D.) **smooth bore hose** (Part not included.).
Use All-Stainless Steel hose clamp (Part not included).

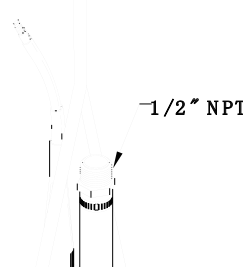

4) Hook-up Safety Line (Sling) (Fig. 7).

CAUTION: Safety line (Sling) should be Corrosion resistant.

- a) Insert safety line (Part not included) through lift plate holes.
- b) Fasten line with appropriate connection approximately 1-2 ft (30 - 60 cm) above the pump.

5) Band the Hose, Safety Line, and Electrical Cable (Fig. 8).

Tie the drop lines together using tie wraps every 6ft. (1.8 m).

This banding will prevent unnecessary damage to the lines during Installation and Removal of pump.

6) Install Pump (Fig. 8).

Note: Prior to installing the pump, fill in the application worksheet on pages 14-15.

The application worksheet is a guide to make sure that the pump is installed properly in the well.

Following the guidelines laid out in the application worksheet will allow the pump to perform efficiently and extend the life of the unit.

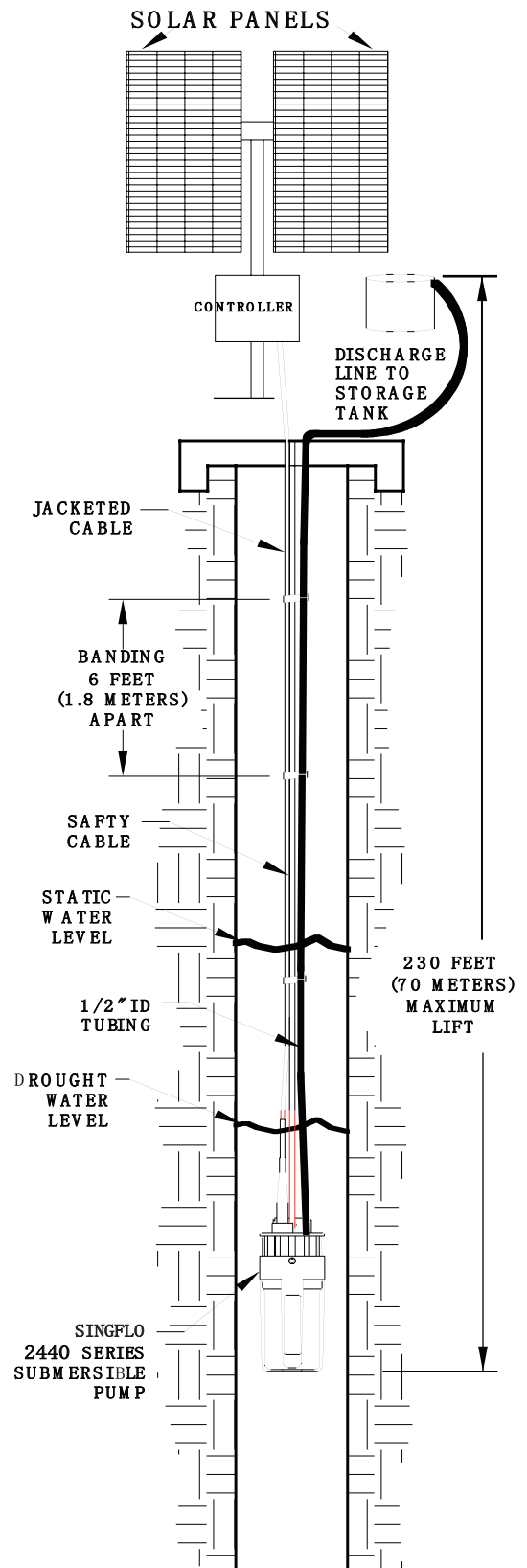

FIGURE 8

Refer to "**Helpful Hints**" if you experience any difficulties.

PARTS LIST

<u>ITEM</u>	<u>DESCRIPTION</u>	<u>QUANTITY</u>
A	CABLE [NOT INCLUDED]	1
B	INNER CABLE BOOT	1
C	OUTER CABLE BOOT	1
-	PLUG (CABLE ADAPTER) [NOT SHOWN]	1
-	SCREW (PLUG) [NOT SHOWN]	2
D	NUT	1
E	SCREW (LIFT PLATE)	6
F	LIFT PLATE	1
G	OUTLET FITTING	1
H	O-RING (OUTLET FITTING)	1
I	O-RING (LIFT PLATE)	3
J	RECEPTACLE (CABLE ADAPTER)	1
K	SET SCREW (RECEPTACLE)	2
L	SCREW (MOTOR)	3
M	FILTER SCREEN	1
N	UPPER HOUSING	1
O	O-RING (UPPER HOUSING)	2
P	SPRING (BYPASS)	3
Q	POPPET (BYPASS)	3
R	VALVE HOUSING ASSEMBLY	1
S	LOWER HOUSING ASSEMBLY	1
T	MOTOR	1
U	CANISTER	1
V	SCREW (CANISTER)	3
W	LOCK WASHER (MOTOR SCREW)	3

REPLACEMENT PART KITS

24-135-00	LIFT PLATE *[E,F,I]
24-136 -00	CABLE PLUG KIT *[B,C,D,J,K,PLUG(CABLE ADAPTER) W/ SET SCREWS]
24-137 -00	VALVE ASSEMBLY KIT *[O,P,Q,R]
24-138 -00	LOWER HOUSING ASSEMBLY KIT *[O,S]
24-139 -00	MOTOR KIT *[O,T]
24-140 -00	CANISTER KIT *[O,U,V]
24-141 -00	FILTER SCREEN KIT *[M]
24-142 -00	O-RING KIT *[H,I,O,O-RING(VALVE HOUSING ASSEMBLY)]
24-143 -00	TOOL KIT *[5/64", 5/32" and 3/16" ALLEN WRENCHES, #1 and #2 PHILLIPS SCREWDRIVERS]

*[] DENOTES PARTS INCLUDED IN KITS.

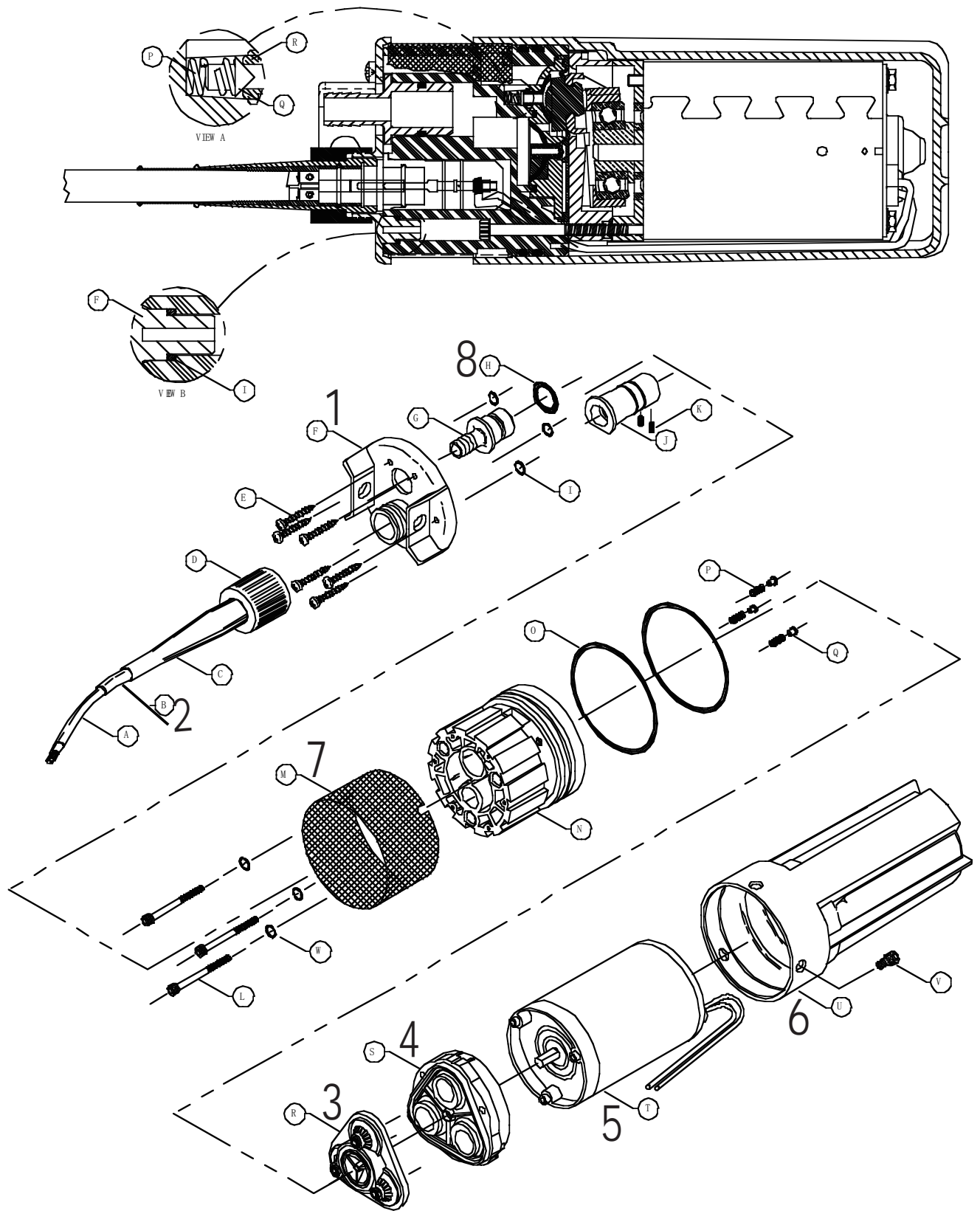

1	2	3	4	5	6	7	8
Lift Plate	Cable Plug	Valve	Lower Housing	Motor	Canister	Filter Screen	O-Ring
24-135-00	24-136-00	24-137-00	24-138-00	24-139-00	24-140-00	24-141-00	24-142-00

BEFORE REQUESTING SERVICE

"Helpful Hints"

<u>SYMPTOM</u>	<u>PROBABLE CAUSE</u>	<u>CORRECTION</u>
<u>PUMP OPERATES but: NO FLOW or REDUCED FLOW</u>	1) LOW VOLTAGE	1) CHECK POWER SUPPLY FOR PROPER VOLTAGE. REFER TO TECHNICAL SPECIFICATIONS (Pg. 16).
	2) NO WATER AT PUMP	2) MAKE SURE THE PUMP IS INSTALLED BELOW THE LOWEST ANTICIPATED WATER LEVEL. REFER TO INSTALLATION SECTION (Pg. 5).
	3) PUMP LOCATED TOO DEEP	3) REFER TO INSTALLATION SECTION (Pg. 5) FOR PUMP OPERATING RANGE.
	4) CLOGGED FILTER SCREEN	4) REMOVE FILTER SCREEN AND RINSE. REFER TO REMOVAL AND DISASSEMBLY SECTION (Pg. 9).
	5) FLUID PATH IN PLUMBING RESTRICTED	5) CHECK FOR PINCHED HOSE, CLOGGED LINES.
	6) LOOSE CONNECTIONS or PUNCTURED HOSE.	6) CHECK HOSE CLAMPS or REPLACE HOSE (Pg. 4).
<u>PUMP WILL NOT OPERATE:</u>	1) INCORRECT POWER SUPPLY	1) CHECK POWER SUPPLY. REFER TO PUMP TECHNICAL SPECIFICATIONS (Pg. 16).
	2) WIRE CONNECTIONS	2a) CHECK ELECTRICAL CONNECTIONS ON SYSTEM.
		2b) CHECK THE PLUG(CABLE ADAPTER) ELECTRICAL CONNECTION MADE DURING THE INSTALLATION IS NOT CORRODED OR LOOSE. REFER TO CABLE BOOT INSTALLATION INSTRUCTIONS FOR DISASSEMBLY AND REASSEMBLY(Pg. 3-4).
	2c) CHECK FOR BLOWN FUSES IN-LINE.	

CONTACT AN AUTHORIZED DISTRIBUTOR FOR FURTHER ASSISTANCE.

II. PUMP REMOVAL AND DISASSEMBLY

For servicing using Replacement Part Kits.

Warning: Make sure all electrical power is off and the Hose (Pipe) is not under pressure.

Warning: Canister maybe pressurized, disassemble the pump in proper order. Follow the manual directions carefully.

Note: Keep all of the parts clean after disassembly.

Upper Housing Assembly contains small parts.

Be careful not to lose parts after removing Upper Housing (Part N) step 9.

1) Remove the Pump from the well.

To prevent damaging the Electrical Connection during removal from well
DO NOT PUT STRESS ON THE ELECTRICAL CORD.

2) Disconnect the Hose.

Remove the Hose clamp, pull and twist the hose to remove it from the fitting.

3) Unplug the Cable Adapter Assembly (Fig 9).

Remove the Nut (Part D) unscrewing it counterclockwise and pull the plug up.

4) Remove the Lift Plate (Part F) (Fig. 9).

Using a #2 Phillips Screwdriver remove the screws (Part E) from 6 places and pull up the Lift Plate.

Note: Be sure to put the O-Rings (Part I) back on the Lift Plate Posts (Fig. 9, View B) before continuing to step 5. If necessary, the filter screen may be removed for cleaning at this stage of the disassembly.

5) Remove the Outlet Fitting (Part G) (Fig. 9).

Remove the fitting from the Upper Housing (Part N) by pulling it straight out.

6) Remove the Receptacle (Cable Adapter) (Part J) (Fig. 9).

Note: DO NOT PULL ON THE ELECTRICAL PRONGS.

- Using pliers **carefully** pull up on the shoulder of the Receptacle (Cable Adapter) and pull it completely out of the Upper Housing (Part N).
- Using a 5/64" Allen Wrench, loosen the screws holding the motor leads (Part k) from 2 places and disconnect the Receptacle (Cable Adapter).

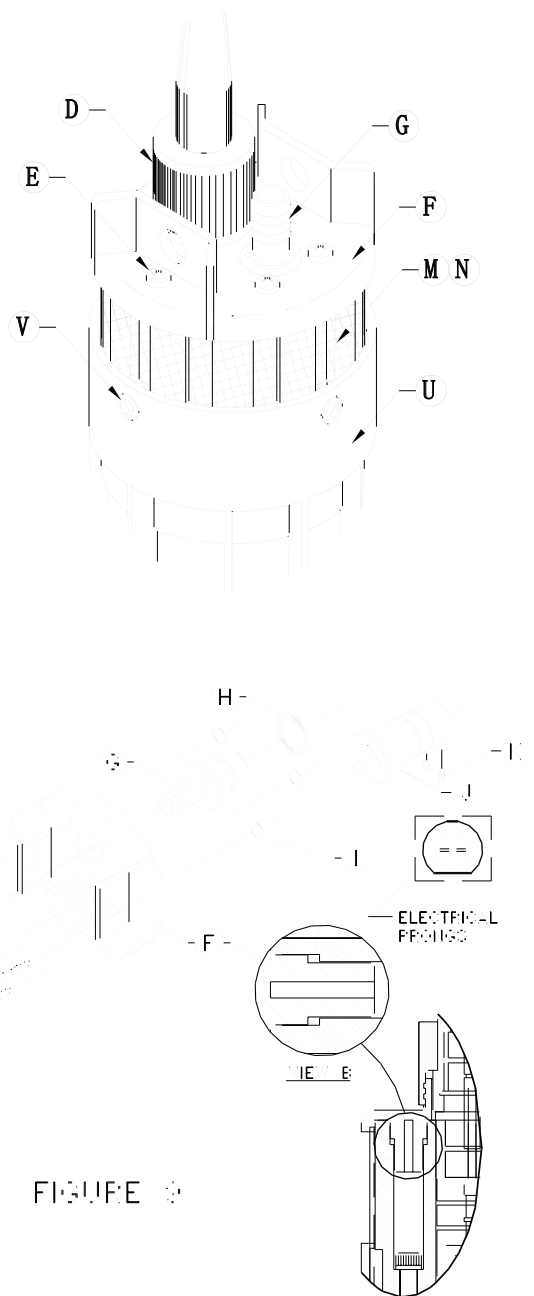

7) **Slide off the Filter Screen (Part M) (Fig. 10).**

8) **Remove the Canister (Part U) (Fig. 10).**

- a) Using a 3/16" Allen Wrench remove the screws (Part V) from 3 places.
- b) Place one hand on the Upper Housing and the other on the Canister. Twist and pull the Assembly apart.

9) **Remove Upper Housing (Part N) and Motor (Part T) (Fig. 10).**

Note: Keep all parts clean after disassembly.

The Upper Housing Assembly contains small parts.

Be careful not to lose parts after removing Upper Housing.

- a) Using a 5/32" Allen Wrench remove the screws (Part L) from 3 places.
- b) Before separating the Upper Housing from the Motor, place the assembly on the Upper Housing(Down) and the Motor facing up.
- c) Separate the Upper Housing, Valve Housing and Lower Housing Assembly (Parts R, S), Poppets (Part Q), and Springs (Part P).

10) **Contact an authorized distributor for assistance with diagnosis and replacement Parts (Refer to page 6 for replacement part kit list).**

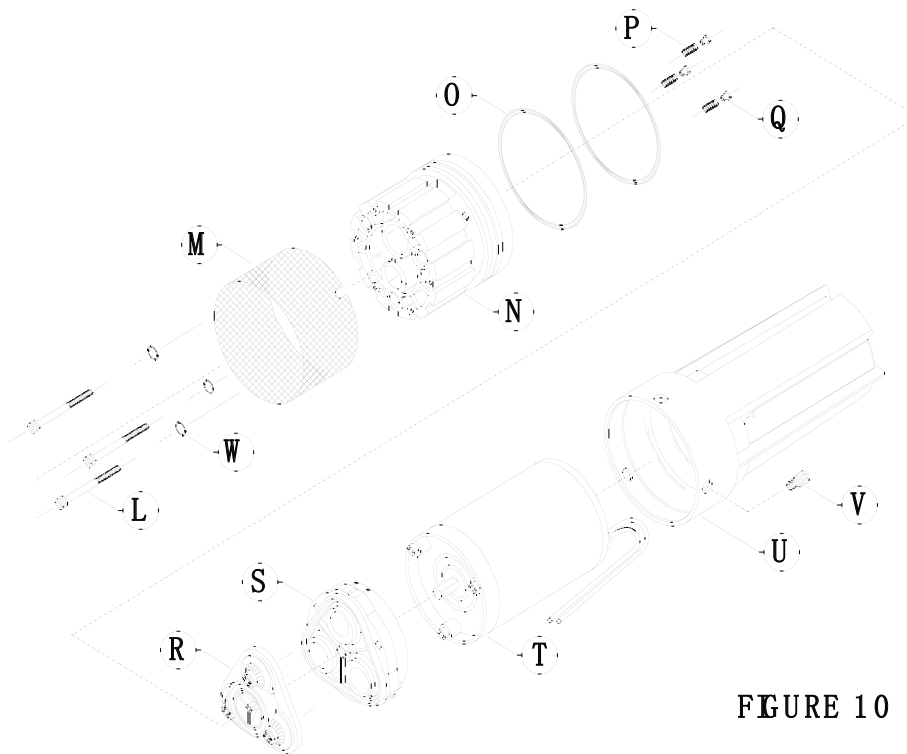

FIGURE 10

III. PUMP RE-ASSEMBLY

Warning: The order of Assembly is important to ensure proper sealing.

1) Install the Upper Housing Large O-Rings (Part O) (Fig. 11).

- a) Remove the existing Large O-Rings and thoroughly clean the O-Ring grooves with a dry cloth and a cotton tipped applicator.

Note: Lubricate the O-Rings with the Supplied O-Ring Grease. **DO NOT** USE PETROLEUM BASED LUBRICANT.

- b) Slide the two new Large O-Rings over the Upper Housing (Part N) and into the O-Ring grooves.
- c) Place the Upper Housing down with the internal cavities exposed. Turn the Upper Housing until the motor wire holes are directly in front.

2) Install the Bypass Assembly (Parts P and Q) (Fig. 11).

- a) Place the Poppets (Part Q) into the Springs (Part P).

Note: Make sure that the Poppets are seated flush against the Springs.

- b) Locate the three bypass cavities and place the Spring/Poppet Assembly into the cavities with the **Poppet up**.

3) Install the Valve Housing Assembly (Parts R) (Fig. 11).

Place the Valve Housing Assembly into the Upper Housing (Part N).

Note: Make sure that the inlet valves are centered on top of the bypass Poppets (Part Q).

4) Install the Lower Housing Assembly (Part S) (Fig. 11).

- a) Place the Lower Housing Assembly onto the Valve Housing Assembly (Part R) (Fig. 11).

Note: **DO NOT** FORCE THE ASSEMBLY. IT SHOULD SNAP TOGETHER EASILY IN ORDER TO SEAL PROPERLY.

5) Install the Motor (Part T) (Fig. 11).

- a) Lubricate the motor shaft with a small amount of general purpose grease.
- b) Align the "D" flat of the motor shaft with the "D" flat on the Lower Housing Assembly (Part R).
- c) Align the motor lead wires with the Upper Housing (Part N) wire holes. Align the three tabs on the motor with the holes on the Lower Housing Assembly (Parts R) and set the motor onto the Lower Housing.

- d) Insert the motor lead wires into the Upper Housing motor wire holes. Push the wires until they touch the surface that the Upper Housing is resting on.

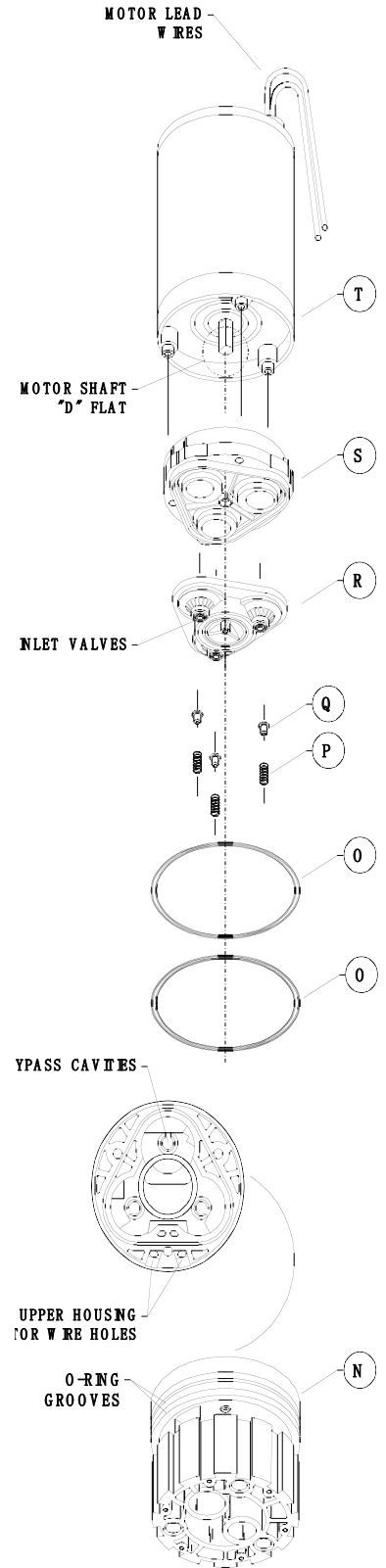

FIGURE 11

6) Install the Canister (Part U) (Fig. 12).

- a) Clean the inside of the Canister with a dry cloth.
- b) Align the wire channel in the canister with the motor lead wires.
- c) Slide the canister over the entire assembly .
- d) Twist the canister to align the screw holes and carefully press on end to seat properly.

7) Install the Screws (Part V) (Fig. 12).

Note: **DO NOT** USE MORE THAN 15 (± 5) in lb [1.7 Nm ($\pm .5$)] torque TO PREVENT STRIPPING.

Using a 3/16" Allen Wrench tighten the screws in 3 places into the Upper Housing (Part N).

8) Turn the assembly over as shown in Figure 13.

9) Install the Lock Washers (Part W) and Screws (Part L) (Fig. 13).

- a) Slide the three Lock Washers onto the screws and place the screws in 3 places into the Upper Housing (Part N).

Note: **DO NOT** COMPLETELY TIGHTEN ONE SCREW AT A TIME.

TIGHTEN THE SCREWS WITH TWO PASSES SLOWLY COMPRESSING THE ASSEMBLY TOGETHER.

- b) Using a 5/32" Allen Wrench tighten the screws on the first pass with 25 (± 5) in lb [2.8 Nm ($\pm .5$)] torque.
- c) Tighten the screws on the second pass with 65 (± 5) in lb [7.3 Nm ($\pm .5$)] torque.

10) Connect the Receptacle (Cable Adapter) (Part J) (Fig. 14, page 13).

Note: The orientation of the motor lead wires will not effect the pumps performance.

- a) Pull the motor lead wires up through the Upper Housing (Part N) and insert them into the Receptacle (Cable Adapter).
- b) Using a 5/64" Allen Wrench hand tighten the screws on the Receptacle (Cable Adapter) for both wires.

Note: **DO NOT** TIGHTEN WITH A POWER TOOL.

- c) Lubricate the outer surface of the Receptacle (Cable Adapter) with the Supplied O-Ring grease.
- d) Match the flat side of the Receptacle (Cable Adapter) with the flat side of the hole in the Upper Housing.
- e) Push the Receptacle (Cable Adapter) into the hole in the Upper Housing until it is seated flush.
- f) Spread each Receptacle (Cable Adapter) electrical prong slightly to insure the electrical connection.

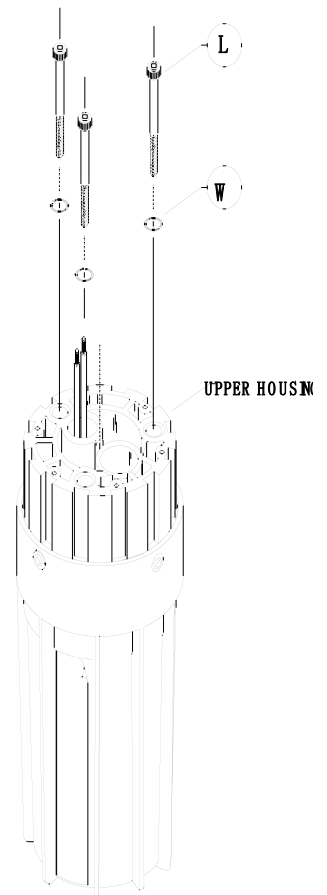

FIGURE 13

11) Install the Filter Screen (Part M) (Fig. 15).

- a) Slide the Filter Screen onto the Upper Housing (Part N).
- b) Align the slots in the Filter Screen with the screws (Part V) in the Upper Housing and slide the Filter Screen over the screws.

12) Install the Outlet Fitting (Part G) (Fig. 15).

- a) Lubricate the O-Ring (Part H) and slide it into the O-Ring groove on the Outlet Fitting.
- b) Push the Outlet Fitting into the hole in the Upper Housing (Part N).

13) Install the Lift Plate (Part F) with three the O-Rings (Part I) on the posts (Fig. 15).

- a) Align the three posts with the Upper Housing (Part N) screw holes and press on the Lift Plate until it is flush against the Upper Housing.

Note: DO NOT USE MORE THAN 20 (± 5) in lb [2.25 Nm ($\pm .5$)] TORQUE TO PREVENT STRIPPING .

- b) Using a #2 Phillips Screwdriver install the screws (Part E) 6 places into the Lift Plate.

14) Install the Plug (Cable Adapter) Assembly.

Note: The orientation of the Plug(Cable Adapter) will not effect the pumps performance.

Note: IF IT BECOMES NECESSARY TO REASSEMBLE THE PLUG (CABLE ADAPTER) ASSEMBLY, REFER TO PUMP CONNECTIONS & INSTALLATION INSTRUCTIONS (Pg. 3-5).

- a) Align the Plug (Cable Adapter) connector holes with the electrical prongs in the Receptacle (Cable Adapter).
- b) Push the Plug (Cable Adapter) into the Receptacle (Cable Adapter) until the collar is seated flush.
- c) Push the Nut (Part D) over the Plug (Cable Adapter) and finger tighten the nut.

Note: Before placing the pump back into the well, operate the pump to check all electrical connections using the correct power supply.
Refer to Technical Specifications (Pg. 14).

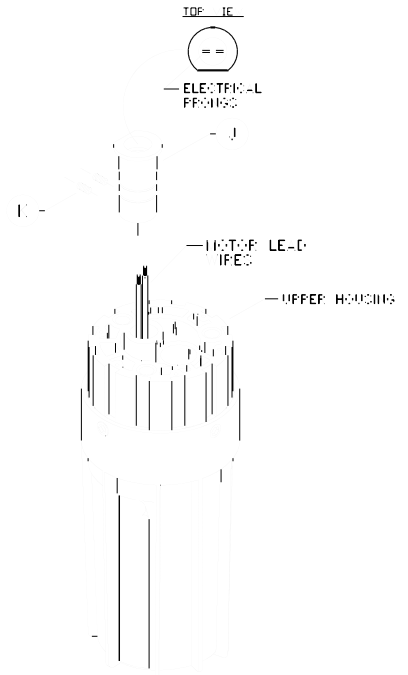

FIGURE 14

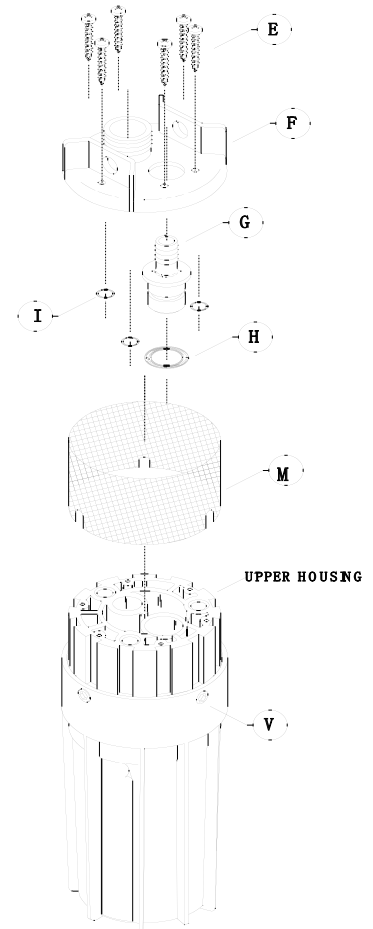

FIGURE 15

APPLICATION WORKSHEET

Please fill in for your records.

MODEL NUMBER _____

SERIAL NUMBER _____

MFG. DATE _____

PURCHASE DATE _____

TOTAL WELL DEPTH _____ FT(M)

WELL RECOVERY

RATE _____

PUMP DISTRIBUTOR:

Name _____

Address _____

City _____

Phone() _____

SOLAR ARRAY INFORMATION:

MAKE/MODEL _____

WATTS AVAILABLE (NO. OF PANELS X WATTS PER PANEL=) _____

CONTROLLER INFORMATION:

MAKE/MODEL _____

NOTE: Use of an LCB (Linear Current Booster) Unit is required for optimum performance.

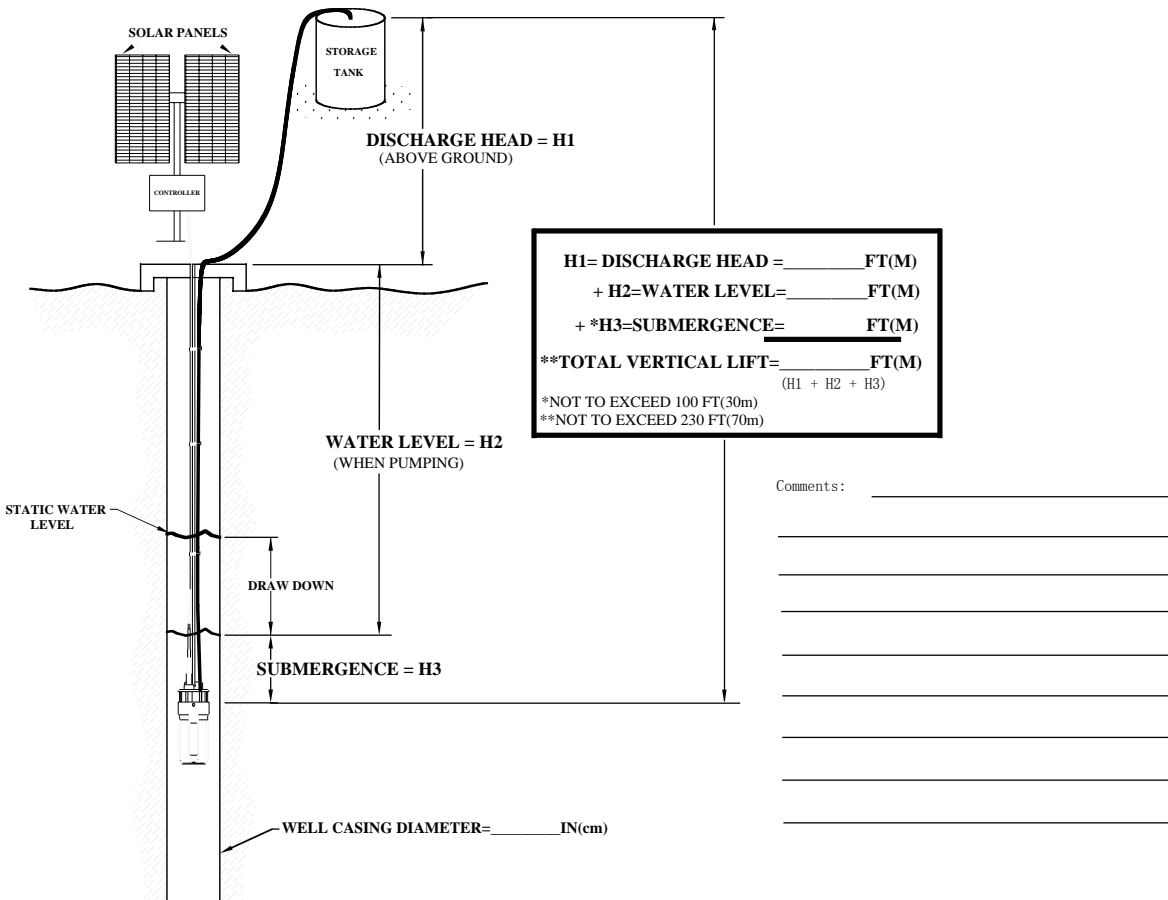

TERMS:

H1=DISCHARGE HEAD = Vertical distance in feet from ground level to level of water in elevated storage tank.

H2=WATER LEVEL = Vertical distance in feet from level of water in well when pumping up to ground level.

H3=SUBMERGENCE = Vertical distance in feet from level of water in well when pumping, to pump position in well.

Note: DO NOT submerge the pump deeper than necessary unless the water level is known to be highly variable (Pump may operate dry for short periods of time.).

Draw down = Vertical distance in feet from static water level to water level when pumping.

Note: Make sure the pump is installed below the lowest anticipated water level.
Consider the seasonal changes in the region.

TOTAL VERTICAL LIFT= H1+H2+H3

12 VDC FLOW CHART

TOTAL VERTICAL LIFT		FLOWRATE PER HOUR		SOLAR ARRAY SIZE MINIMUM TOTAL POWER RATING	CURRENT AMPS
FEET	METERS	GAL	LTR	WATTS	
20	6.1	56	212	22	1.2
40	12.2	54	204	28	1.5
60	18.3	52	197	33	1.8
80	24.4	50	189	37	2.0
100	30.5	49	186	40	2.1
120	36.6	47	178	45	2.4
140	42.7	46	174	51	2.7
160	48.8	44	166	56	3.0
180	54.9	43	163	61	3.3
200	61.0	41	155	64	3.4
230	70.1	36	136	72	3.9

24 VDC FLOW CHART

TOTAL VERTICAL LIFT		FLOWRATE PER HOUR		SOLAR ARRAY SIZE MINIMUM TOTAL POWER RATING	CURRENT AMPS
FEET	METERS	GAL	LTR	WATTS	
20	6.1	117	443	58	1.5
40	12.2	114	432	65	1.7
60	18.3	109	413	78	2.1
80	24.4	106	401	89	2.4
100	30.5	103	390	99	2.6
120	36.6	101	382	104	2.8
140	42.7	99	375	115	3.1
160	48.8	98	371	123	3.3
180	54.9	93	352	135	3.6
200	61.0	91	345	141	3.8
230	70.1	82	310	155	4.1

TECHNICAL SPECIFICATIONS:

MODEL NUMBER: YM 2440-30

PUMP DESIGN: Positive Displacement
3 Chamber Diaphragm Pump

CAM: 3.0 Degree

MOTOR: Permanent Magnet, P/N 11-175-00
Thermally protected

VOLTAGE: 24 VDC Nominal

WATTS: 120W

AMPS: 4.0 MAX

FUSE: 7.5 AMP (Automotive)

INTERNAL BYPASS: 105-110 P.S.I. MAX (7.2-7.5 bars)

MAXIMUM LIFT: 230 ft (70 M)

MAXIMUM SUBMERSION: 100ft (30 M)

OUTLET PORT: 1/2" (12.7 mm I.D.) Barbed Fitting
for 1/2" I.D. (12.7 mm I.D.)Tubing.

INLET: 50 MESH STAINLESS STEEL SCREEN

MATERIALS: HIGH STRENGTH ENGINEERED PLASTICS
and STAINLESS STEEL FASTENERS

TYPICAL APPLICATIONS: Potable water well pump.

NET WEIGHT: 6 lbs (2.72 kg)

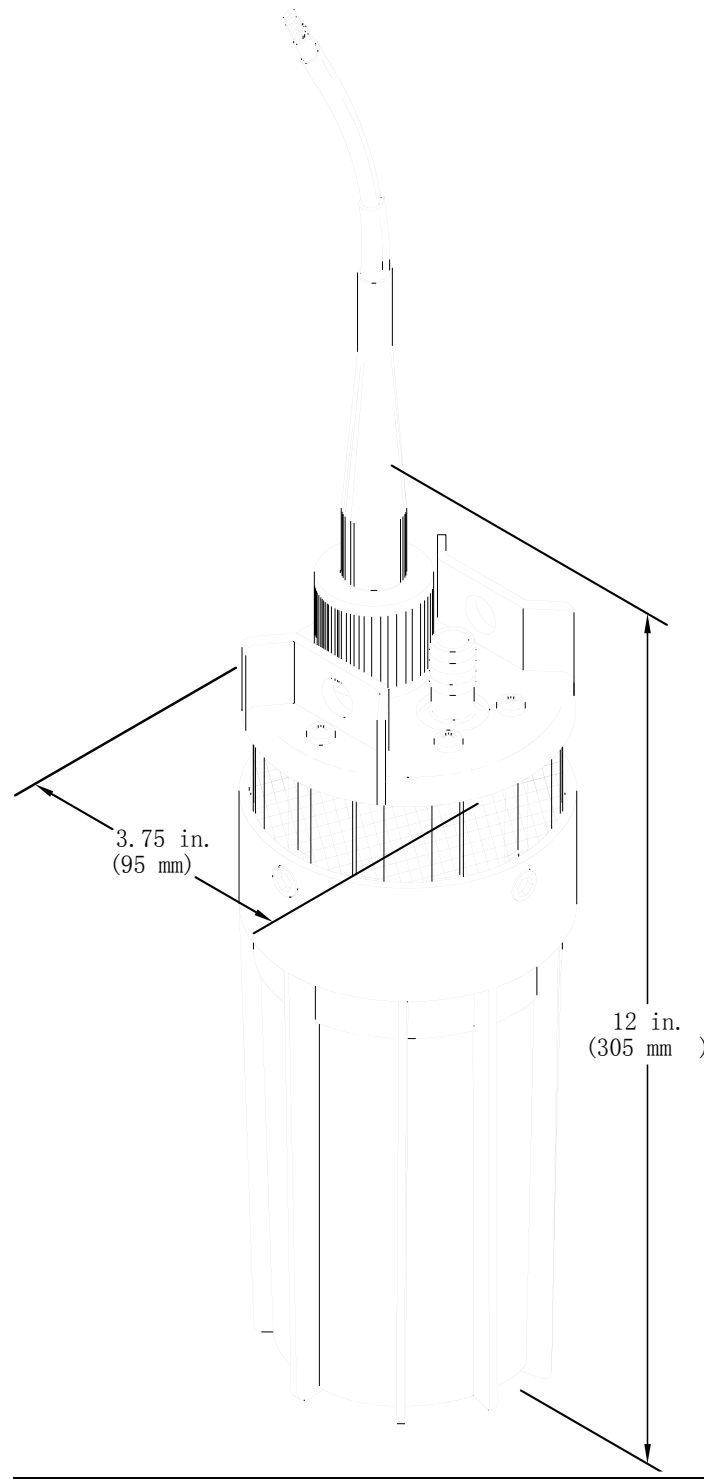

DIMENSIONS: Inches(Millimeters)

Design and specifications are subject to
change w/o notice.

WARRANTY

LIMITED WARRANTY PROCEDURE

SINGFLO warrants its pump to be free of defects in material and workmanship to the original retail purchaser for the period of one year beginning with the purchase date of the unit or, in the absence of proof of purchase date, one year from the date of manufacture as shown on the pump, not to exceed two (2) years in any event. Each pump has been operated and tested before being shipped from SINGFLO's factory. During the warranty period if the pump is not operating correctly, you may return it freight pre-paid to your local distributor, dealer or directly to SINGFLO.

Upon SINGFLO's inspection, any unit found faulty due to manufacturing defects will be repaired or replaced at no charge. This warranty does not apply to any damage resulting from misuse, negligence, accidents, improper installation or wiring. Abuses such as removal of the SINGFLO label, improper repair, installation, application, or damaged lower housing assembly due to running dry, are also not considered warrant able. There will be charges applied for any of the above mentioned non-warrantable items.

If you send the pump to us for prompt repair, please package it carefully to avoid shipping damage. Enclose your name, address, a phone number where you may be reached and your proof of purchase date.

The above represents our warranty policy. Under no circumstances will we assume or accept responsibility for unauthorized expenditures, losses, or any costs greater than the basic pump value.